

New

## BCBM-50KW-001

50kW 8:4 620 $\mu$ H

INDUCTIVE COMPONENTS / OFFBOARD CHARGER TRANSFORMERS

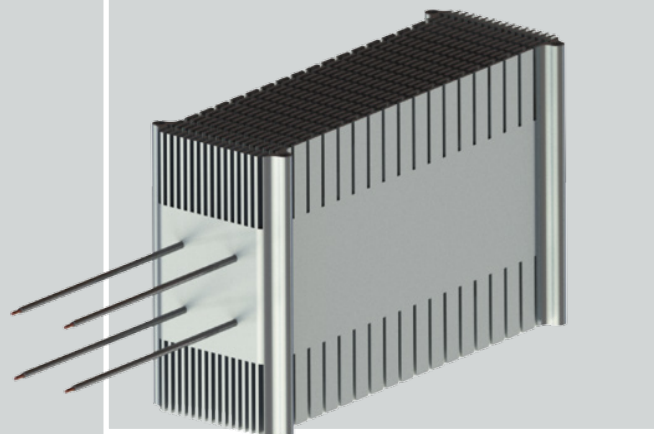

### APPLICATIONS

- › TRSET 50kW 8:4 Lp620UH Lkp/Lks 32 $\mu$ H/8 $\mu$ H

### 01 FEATURES

- › A total 50 kW part enclosed in a whole aluminum housing and filled with thermal compound.
- › Operating temperature -40 to 150°C
- › Approx weight: 740g

### 02 SPECIFICATIONS

#### DIMENSIONS (mm)

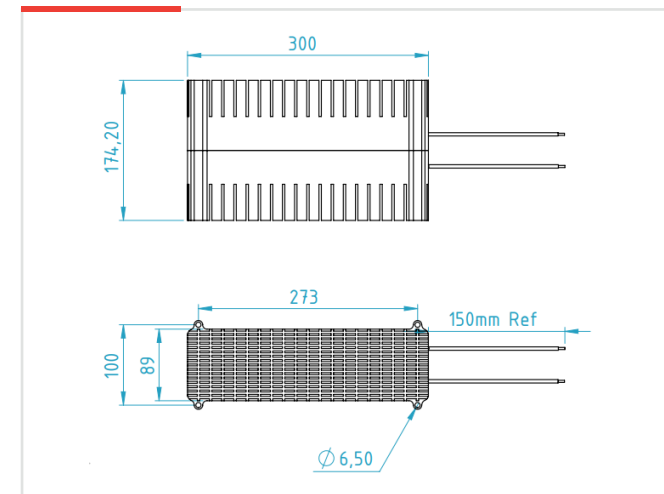

#### ELECTRICAL DIAGRAM

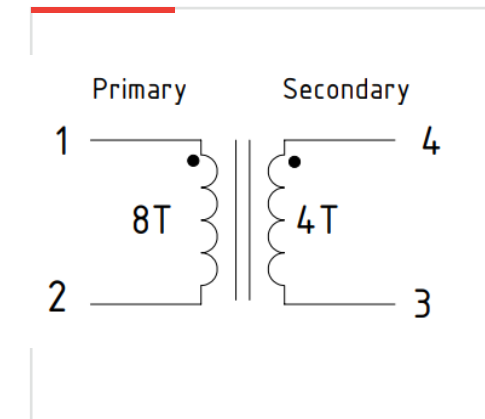

#### ELECTRICAL SPECIFICATIONS

TURN RATIO	
	8:4
INDUCTANCE	
Primary Inductance	(1-2): 620 $\mu$ H $\pm$ 10%
Secondary inductance	(3-4): 155 $\mu$ H $\pm$ 10%
LEAKAGE INDUCTANCE	
(1-2, 3-4 shorted)	32 $\mu$ H $\pm$ 5%
DC RESISTANCE	
1-2	4 mOhm typ
3-4	2 mOhm typ
DIELECTRIC STRENGTH	
Primary to secondary winding	4000 Vac (50/60Hz; 5mA; 2sec)