

# 3DC11F

## SMD Foam Label 3D Coil Low Profile

13x11.6x4.35mm (2.38mH - 7.2mH)

3-AXIS TRANSPONDER INDUCTOR (3DCOILS™)



### APPLICATIONS

- › Automotive Passive keyless entry systems.
- › Automotive RTPMS with wake up functions.
- › Industrial logistics and control.
- › Access control.
- › Tracking devices.

## 01 CHARACTERISTICS

- › Evolution of the 3DC11LP series.
- › The foam, placed on the top of the part, absorbs better the shocks and, thus, improves the mechanical performance of the piece.
- › Very good electrical performance.
- › High stability in temperature (-40°C to +85°C).
- › High sensitivity values.
- › The inductivity in each axis can be customized to achieve customer requirements.
- › Designs at lower frequencies, 20 kHz or 40 kHz, show a very good electrical performance as well.

## 02 SPECIFICATIONS

### DIMENSIONS AND RECOMMENDED PAD-LAYOUT (mm)

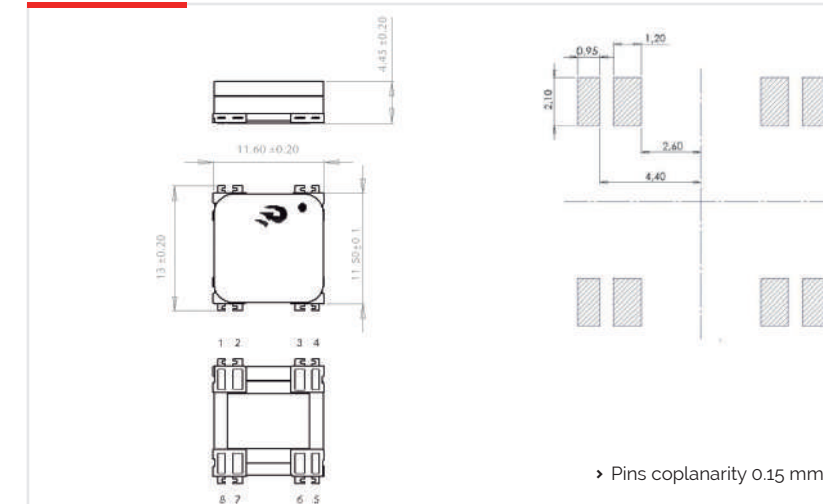

### ELECTRICAL DIAGRAM

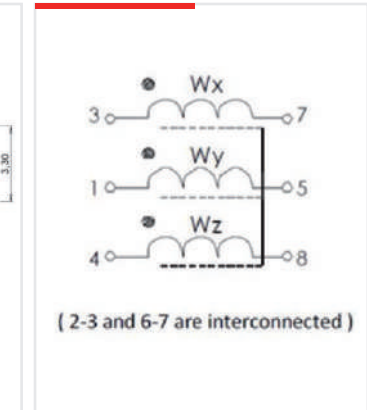

### ELECTRICAL SPECIFICATIONS

P/N	L x,y,z (mH)	Q x,y,z Min	Frequency (kHz)	Cres(pF)	SRFx,y (kHz) Min	SRFz (kHz) Min	DCR x,y (Ω) Max	DCR z (Ω) Max
3DC11F-0238J	2.38	18	125	680	450	900	60,5	82,5
3DC11F-0491J	4.91	18	125	330	300	600	100	160
3DC11F-0720J	7.20	15	125	225	250	500	165	209

P/N	Sensitivity x,y,z (mV/A/m) Min	Length (mm)	Width (mm)	Height (mm)
3DC11F-0238J	40	13,0	11.6	4.35
3DC11F-0491J	70	13,0	11.6	4.35
3DC11F-0720J	85	13,0	11.6	4.35

This chart is a reference guide for the most common required values at working frequency of 125 kHz. Any other inductance value at LF or tighter tolerances can be provided. Also can be supplied different inductance values in the different winding axis. **Please contact our sales department for any inquiry.**

L and Q factor measured at 125 kHz, 1 Vac.

Sensitivity measured with Helmholtz coils H=8.36 App/m @125 kHz. Contact us for measurement specification.

SRF: Self Resonant Frequency of the coil.